

PROBE ENGINEERING, INC.

Installation Instructions

Model BT-45E Electronic Ignition

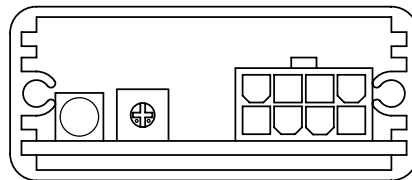

Control Module

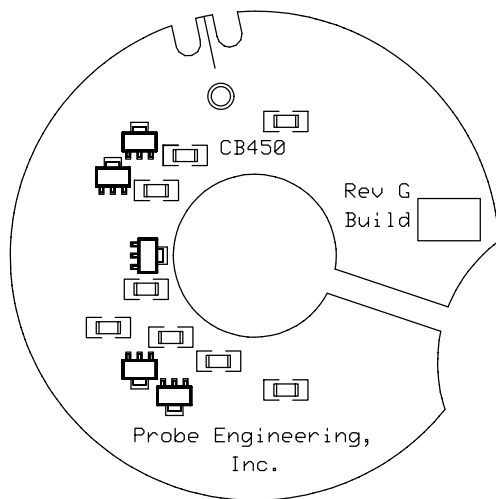

Pickup Plate

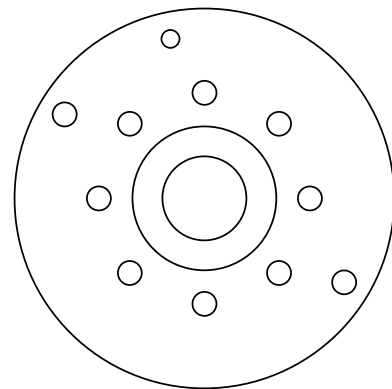

Trigger Rotor

PROBE ENGINEERING, INC.

Installation Instructions, Model BT-45E Version 3.2

The Model BT-45E electronic ignition is designed specifically for 1960s and 1970s Honda CB450, CL450, and CB500T motorcycles using derivatives of Honda's U.S.-version 180° crankshaft twin-cylinder engine. The Model BT-45E ignition is not intended for the 360° crankshaft Japanese-market CB450 engine. The two CB450 variants can be easily told apart; the 180° crankshaft U.S. version has two sets of ignition breaker points and two separate coils, while the 360° crankshaft Japanese version has one set of breaker points and one dual-tower coil.

Table of Contents

Removing points and condensers	Step 1 - Step 14
Installing Pickup Plate and Trigger Rotor	Step 15 - Step 24
Installing Pickup Plate terminals in connector housing	Step 25 - Step 28
Identifying Control Module	Step 29 - Step 30
OPTIONAL racer degree-wheel timing method	Step 31 - Step 41
Mounting the Control Module	Step 42 - Step 44
Connecting the Power Cable Harness	Step 45 - Step 53
Spark test - checking that everything works	Step 54 - Step 58
Starting engine & finalizing timing w/ Xenon light	Step 59 - Step 68
Appendix 1, Kill Switch and Tachometer Options	Page 13, 14
Other Details and Notes; Contact Info	Page 15

What should be in the kit:

The Model BT-45E kit includes the following components:

- ◆ Control Module
- ◆ Pickup Plate (with wire harness)
- ◆ Pickup Plate Spacer
- ◆ Pickup Plate Connector Housing
- ◆ Trigger Rotor
- ◆ Power Cable Harness
- ◆ Pair of NGK BR8ES spark plugs (the use of resistor-type plugs is required)
- ◆ M6 by 12mm screws with rubber-faced flat washers (for retaining the Pickup Plate)
- ◆ 9V battery adapter harness (for optional static-timing procedure)
- ◆ Spare white and orange wires (1-foot long each, for optional features)

PROBE ENGINEERING, INC.

Installation Instructions, Model BT-45E Version 3.2

What else you will need:

In addition to the usual small hand tools required to get access to the engine's breaker-points assembly and to remove the fuel tank, side panels, etc., installation will require the following tools and supplies:

- ◆ Solderless crimp-type connectors, bullet connectors, or solder and shrink tubing
- ◆ Loctite® "blue" medium-strength thread-locking compound or equivalent
- ◆ 9V snap-connect type battery (optional, for setting the timing using a degree wheel)
- ◆ Xenon-flash timing light

Installation:

1. Remove the side panels, if applicable (for general access).
2. Remove the seat.
3. Disconnect the battery.
4. Remove the fuel tank (you will need access to the ignition coils).
5. Remove the alternator rotor cover (for setting the timing).
6. Remove the breaker-points cover.
7. Remove the bolt and washer that secure the centrifugal advancer mechanism and put them aside (they will be reused to retain the electronic ignition's Trigger Rotor).
8. Remove the two screws and washers that retain the points backing plate, and put them aside (they will be reused to retain the electronic ignition's Pickup Plate).
9. Disconnect the wires that go from the breaker points to the coils and condensers.
10. Remove the breaker points, backing plate, and wiring as an assembly. You will have to pull the blue and yellow wires and their gray plastic jacket through the hole in the rear surface of the points housing.
11. Remove the grommet from the hole in the rear of the points housing (if it did not come out with the breaker points wiring).

PROBE ENGINEERING, INC.

Installation Instructions, Model BT-45E Version 3.2

12. Disconnect and remove the condensers (they should not be used with the solid-state ignition).
13. Remove the advancer mechanism from the 11mm diameter quill on the end of the camshaft. It may need gentle persuasion in the form of mild heat, penetrating oil, or a puller. If a puller is required, you can loosely reinstall the retaining bolt a few threads shy of full engagement to use as the “push” point.
14. Clean any rust or debris from the cam-end quill and from the seating surface (shoulder) at the base of the quill.
15. Locate the Pickup Plate in the ignition kit. It looks like this:

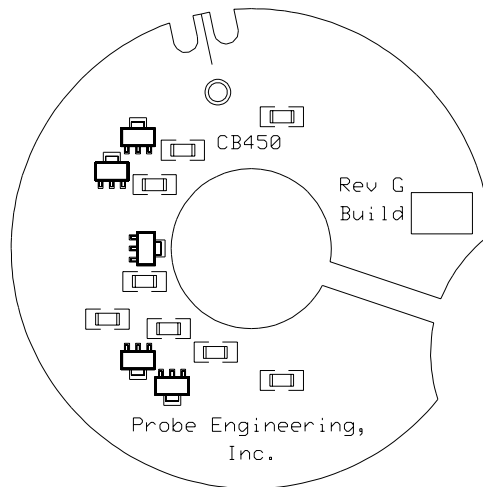

16. Seven Teflon-insulated wires surrounded by a braided-copper shield exit from the back surface of the Pickup Plate. The far ends of the wires have crimped-on terminals, but are not installed in a connector housing, so that they can be fed through the wire lead-out hole at the rear of the points housing. Carefully, using just fingers, feed the wires through the hole. The shield may be slid up along the colored wires (all except the black wire, which is soldered to the shield) to give more free length, so that the wires can be fed through the hole more easily.

PROBE ENGINEERING, INC.

Installation Instructions, Model BT-45E Version 3.2

17. Locate the Pickup Plate Spacer in the kit. It looks like this:

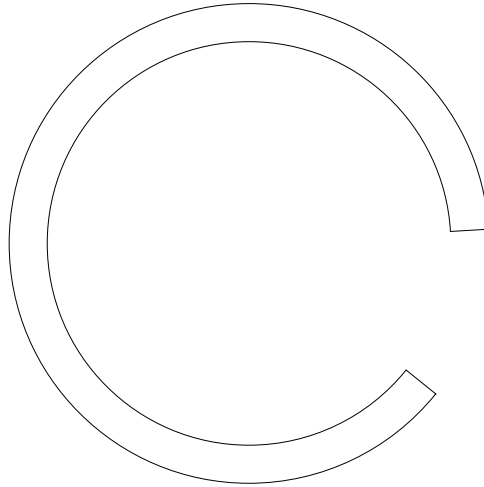

18. Slip the spacer gap around the wire bundle behind the pickup plate, and install the spacer in the original points-plate relief in the housing, oriented as shown in the drawing above; the gap in the spacer straddles the exhaust rocker-shaft locknut.
19. Install the pickup plate on top of the spacer; when the pickup plate is seated, it will be “proud” to the surface of the housing by ten or twenty thousandths of an inch, so that the screws and washers can retain it firmly.
20. Loosely install the two M6 pan head screws with rubber washers supplied in the kit to retain the pickup plate. Tighten just enough so that the spacer and plate won’t fall out of the relief.
21. There is a yellow line on the pickup plate at about the 11:00 position that splits the “adjuster” tongue right up the middle. Position the yellow line so that it’s centered in the adjuster relief cutout in the points housing, and tighten up the two pickup plate retaining screws.

PROBE ENGINEERING, INC.

Installation Instructions, Model BT-45E Version 3.2

22. Locate the Trigger Rotor in the kit. It looks like this:

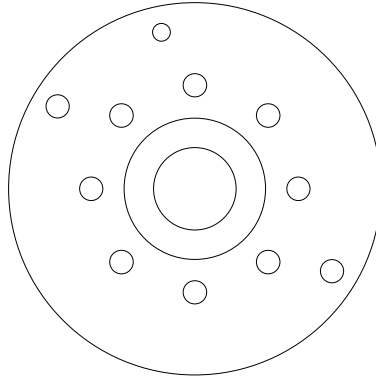

23. The rear hub of the rotor has a notch that locates over the 3mm dowel at the base of the camshaft's 11mm diameter quill; slip the rotor onto the quill and register the notch over the dowel.

24. Using the original retaining bolt and washer from the centrifugal advancer, bolt the trigger rotor in place. It's good practice to use the medium-strength (Loctite "blue" or equivalent) anaerobic thread locker on the trigger rotor retaining bolt.

25. Locate the Pickup Plate Connector Housing in the kit. It has barely-legible numbers molded into the rear flange surface that denote each wire's "position" number. From the wire-entry end, it looks like this:

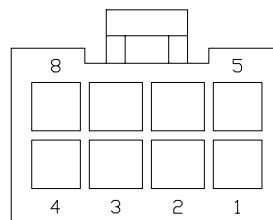

Scale 2:1

26. You are going to install the seven connector terminals of the pickup plate leads into this housing. The terminals insert into this end (this view) of the housing; they push into place and "click" when they are fully inserted and captured.

PROBE ENGINEERING, INC.

Installation Instructions, Model BT-45E Version 3.2

27. The terminals must be correctly oriented in order to install in the housing. From the side view, the terminals look like this:

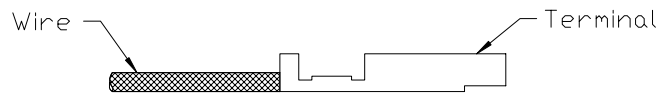

Scale 2:1

Seen from the wire end, the terminals look like this, with a heart-shaped insulation crimp gripping the wire:



Scale 2:1

28. The terminals install into the housing oriented as shown below, with the wire colors in each position as indicated:

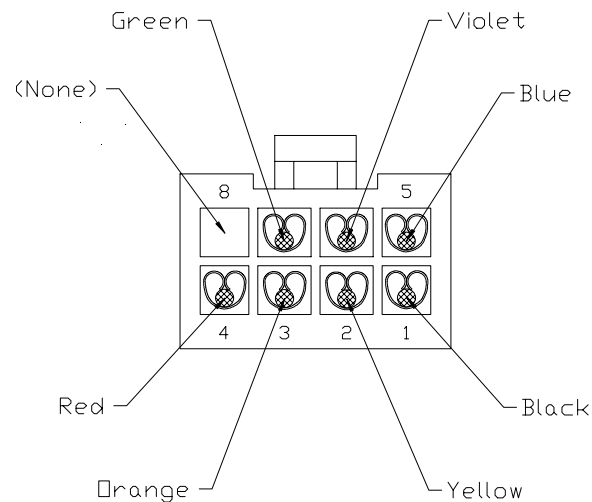

Scale 2:1

When the terminals are correctly oriented, they will slide into the housing without undue force, and will seat with a “click” when fully inserted. To be sure that the

PROBE ENGINEERING, INC.

Installation Instructions, Model BT-45E Version 3.2

terminals are fully seated, compare them to the termination of the Power Cable Harness, which is factory-assembled.

If you have poor color vision, or are otherwise unsure of your ability to get the right color wires in the correct location and the terminals properly inserted, STOP! and get assistance from someone who is equipped to do this step. If the wires are installed into the wrong position and power is applied, the system will not work properly and you may damage the Pickup Plate assembly; such installation damage is NOT covered under warranty.

If a wire color does end up in the wrong position, a terminal extractor tool is available by mail order from Digi-Key Corporation (www.digi-key.com); their part number is **WM9918-ND**. By the time it's in your hands, the extraction tool will cost you about \$30.00 and will not look like a bargain, but there's no other way to get a wrongly located terminal out without destroying the connector, so take your time and get this critical step right the first time.

29. Locate the Control Module in the kit. It looks like this:

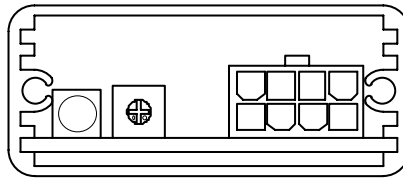

30. There is an 8-pin connector at the right side of the module, a red LED at the left side, and a blue potentiometer between the two. There is also a 6-pin connector (not shown in the line drawing) at the end of a short wire bundle coming out the module. The 8-pin connector into which you just installed the pickup plate wires mates with the 8-pin connector housing in the control module, and the Power Cable Harness mates with the 6-pin connector.

NOTE: The installation steps you've completed to this point have already located the Pickup Plate and Trigger Rotor with sufficient accuracy that you will be able to start and run the engine, after which ignition timing will be finalized using your Xenon-flash timing light. If you are a racer with a non-stock or absent alternator rotor, or are experienced in using a degree wheel to set timing, the following optional steps #31 through #41 will guide you through the process before you complete the rest of the installation. If you are NOT using a degree wheel to set the timing, skip directly to Step #42 now.

PROBE ENGINEERING, INC.

Installation Instructions, Model BT-45E Version 3.2

31. To set the ignition timing using a degree wheel, begin by temporarily hanging the control module somewhere near the left crankcase, so that you can see the module's red LED with your peripheral vision while turning over the engine and watching the degree wheel and timing pointer.
32. Plug the 8-pin connector from the pickup plate assembly into the mating part of the control module.
33. Locate the 9V battery adapter harness in the kit. It has a familiar two-snap connector for a 9V rectangular battery on one end and a 6-pin connector on the other.
34. Snap a fresh 9V battery onto the matching terminals of the connector harness (you do this first, before plugging the harness into the module, so that if you get the battery terminals backward at first, nothing bad will happen).
35. Plug the battery harness into the 6-pin mating part of the control module.
36. Using a socket or box end wrench on the left-hand crankshaft end, rotate the crank slowly counterclockwise while watching the degree wheel, the pointer, and the module's red LED. This will be made easier by first removing the spark plugs, so that you're not working against compression (you will still be working against valve springs, which is trouble enough). If you choose to remove the plugs, be careful not to drop anything down into the cylinders.
37. As you rotate the engine, the red LED on the control module will alternately illuminate and go dark. Lighting up signifies that the left-cylinder's Hall-effect "run" sensor is in the "dwell" mode; this is when coil current will be passing through the coil when the installation is complete and the engine is running.
38. Exactly as the LED goes dark at the end of the dwell mode is when the spark plug for the left cylinder will fire at the full-advance point. *Note that unlike the points-type setup, for which factory-type "static" timing is usually done at the full-retard position, the electronic ignition's timing LED changes state at the full-advance point.* Also note that once the LED goes dark at the "fire" point, you can't get it to re-illuminate by just "backing-up" the crankshaft a few degrees like you can with a points setup; you must continue rotating the crankshaft counterclockwise to get back into dwell mode for the next "fire" event.
39. If the LED goes dark when your degree wheel is exactly at the desired full-advance "fire" position, you can leave everything set up as is. If correction is needed (the more likely case) to get the timing precisely where you want it, loosen the two M6 retaining screws and adjust the pickup plate's position to advance or retard the timing.

PROBE ENGINEERING, INC.

Installation Instructions, Model BT-45E Version 3.2

Rotating the pickup plate clockwise advances the timing, and rotating it counterclockwise retards the timing. For every 0.022" of movement at the edge of the pickup plate, the timing will change by two degrees at the crankshaft.

40. When you've got the full-advance timing set, tighten the two pickup plate hold-down screws.
41. Disconnect the pickup plate wire harness and the 9V battery harness from the control module.

If you're not a racer using a degree wheel to set the ignition timing, resume the installation at Step #42, below:

42. Find a place where you'd like to mount the control module. Now is the time to plan the routing of the wires from the pickup plate to the module; the plate's wire bundle is 36" long end-to-end, so be sure that the module location you select is within reach of the pickup plate wires.
43. The control module is delivered with Velcro fastening material. The "loop" side is attached to the module; the "hook" side has an aggressive "peel-and-stick" adhesive, for attaching to a clean, flat surface on the bike. The module dissipates low power, and will get warm to the touch during operation. It does not require aggressive airflow, but should not be mounted in a sealed volume with no airflow at all.
44. Route the pickup plate assembly's wire bundle to the location of the control module. The pickup plate wires are insulated using high-temperature Teflon, and have a tinned-copper braided shield surrounding them; the wires can be routed pretty much anywhere (except to an exhaust pipe!) without major temperature concerns. *However, the wires must be kept well away from the spark-plug leads, so that the electronics won't get confused or damaged by spark-energy "pickup" from the high-voltage coil leads.*
45. Examine the 6-pin connector at the end of the Power Cable Harness. On the connector's rear surface, where the wires enter, there are (hard-to-see) molded-in numbers showing each wire's position. Numbers 1 through 3 are in the first row (furthest away from the molded-in retaining latch), and numbers 4 through 6 are in the second row. The wires in each position are described in the following table. For the basic system installation, you only have to deal with the four wires shown in **boldface** type:

PROBE ENGINEERING, INC.

Installation Instructions, Model BT-45E Version 3.2

◆ Position 1:	Heavy-gauge red wire – goes to switched +12 volts
◆ Position 2:	Heavy-gauge green wire – goes to chassis ground
◆ Position 3:	Heavy-gauge yellow wire – goes to left-cylinder coil
◆ Position 4:	Heavy-gauge blue wire – goes to right-cylinder coil
◆ Position 5:	Open (reserved for kill-switch option)
◆ Position 6:	Open (reserved for electronic tachometer option)

46. **Important notes:**

- When routing wires, keep the power cable harness wires separated from the pickup plate wires.
 - It is important to keep *all* wires away from the high-voltage spark plug leads. We strongly recommend the use of carbon-type suppression plug wires or modern spiral-wound suppression plug wires with electronic ignition systems.
 - If you cannot use suppression-type wires, you must use resistor plug caps (at least 5k ohm, as the Honda original components).
 - Resistor-type spark plugs are included in the kit, and their use is required. NGK brand plugs will have an “R” in the alpha prefix if they are resistor type; you may prefer to use a different heat-range plug than the included BR8ES, but it should always be a resistor-type.
47. The power cable harness’ heavy-gauge green wire (connector position 2) must go to a good chassis ground. A “good ground” means three things; it must have a low-resistance path to the battery’s negative (-) terminal, it must have low-resistance path to the metal of the main chassis, and it must have a low-resistance path to the cylinder-head. If these three things are not well-connected together electrically, you will have problems. The ground wire is 12” long as supplied. If you want to make it shorter, you may, but it should not be extended.
48. The power cable harness’ heavy-gauge red wire (connector position 1) goes to a switched source of +12 volts. You can pick this up from the wire supplying +12 volts to the ignition coils. On the stock CB/CL450 series, these are black with a white stripe in the original Honda wiring harness; they go to the coils’ positive (+) terminals.
49. The heavy-gauge yellow wire (connector position 3) goes to the negative (-) terminal of the ignition coil for the left cylinder.

PROBE ENGINEERING, INC.

Installation Instructions, Model BT-45E Version 3.2

50. The heavy-gauge blue wire (connector position 4) goes to the negative (-) terminal of the ignition coil for the right cylinder.
51. The following schematic wiring diagram shows how the system connections should be made. For those not familiar with such diagrams, a “dot” where wires meet signifies that they are connected together electrically, while a “jog” signifies that they are not connected.

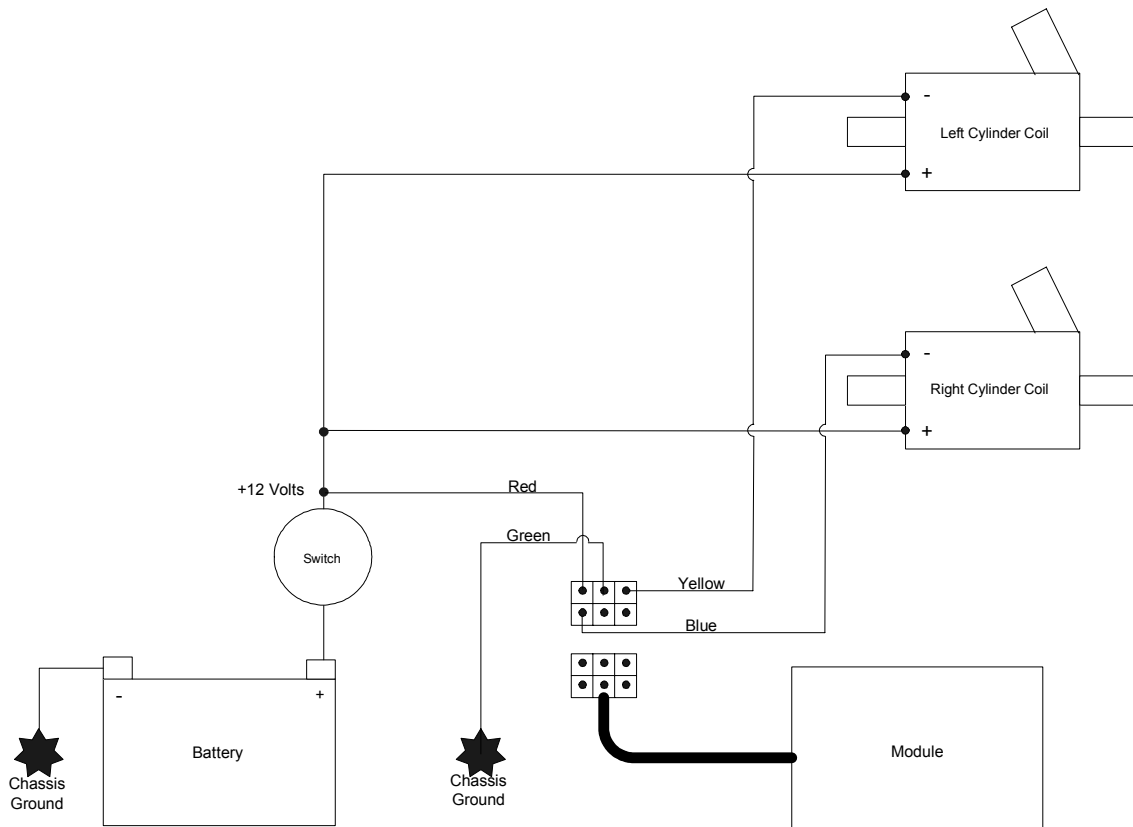

Wiring Diagram

52. Once you've got the pickup plate wire harness and the power cable harness wiring and routing complete, plug the pickup plate and power cable harness connectors into the control module's mating connectors.
53. Reconnect the battery.
54. Disconnect the spark plug caps and remove the spark plugs. Reinstall the caps onto the new BR8ES plugs, and lay the metal base of the plugs down so they contact the

PROBE ENGINEERING, INC.

Installation Instructions, Model BT-45E

Version 3.2

cylinder head surface. **Make sure that the spark plugs are well away from the empty spark plug holes in the head, and that the carburetors and cylinders are “dry” (no fuel), so that you will not ignite fuel vapor with the sparks you are about to create at the plug gaps.**

55. Turn the ignition key to the “on” position (or otherwise energize the ignition with battery power).
56. Rotate the engine through a couple of revolutions while keeping an eye on the spark gaps in the two plugs. Each plug should spark in turn.
57. If both plugs are sparking, switch off the ignition power.
58. Disconnect the spark plugs from the plug caps, install the BR8ES plugs in the engine, and reinstall the plug caps onto the plugs.

If you used the racer/degree-wheel method to set the ignition timing, you may want to skip steps #62 through #68, or else substitute your own timing marks for the factory alternator rotor’s full-advance “hash” marks in the following steps.

59. Reinstall the seat, any side panels, and the fuel tank; open the petcock, and set the choke or enrichener, as required for a cold start.
60. Loosely reinstall the alternator cover; you are about to start and warm up the engine, and this will minimize the oil-fling mess from the “wet” alternator cavity.
61. Start the bike. The kick or electric starter may be used (or bump start, if you’ve built a racer).
62. Warm up the engine, so that it will carburet cleanly.
63. Connect a xenon-flash timing light to the left-hand cylinder’s spark plug wire and to the battery (if required; some timing lights have internal batteries).
64. With the engine stopped, remove the alternator cover again, and restart the engine. Watch out for oil fling.
65. With the timing light operating, slowly rev the engine up about 3,500 RPM. You’ll see the timing advance from somewhere around the “LF” mark (at low speeds) to the full-advance marks; as you approach 3,000 RPM, you’ll see the last degree or two of spark lead come in, and thereafter, there will be no further advance. Since calibration between tachometers is always in question, we’ll measure the full-advance timing at

PROBE ENGINEERING, INC.

Installation Instructions, Model BT-45E Version 3.2

about 3,500 RPM. At 3,500 RPM, the timing light should “freeze” the alternator rotor’s timing indicator between the two full-advance marks. If corrections are needed to get the timing spot-on, make them now; rotating the pickup plate clockwise advances the timing, and rotating it counterclockwise retards the timing.

66. Once the full-advance timing is verified, check the idle-speed timing. Let the engine idle at its recommended idle speed, and shine the timing light on the alternator rotor. You will see the rotor’s nominal “LF” idle-speed timing mark “frozen” somewhere near the fixed reference mark. To finalize idle-speed timing, the module’s blue Idle Timing potentiometer can be used to alter the low-speed timing delay. Turning the potentiometer clockwise increases the timing delay and retards the idle-speed ignition timing; turning the potentiometer counter-clockwise advances the timing.
67. Move the timing-light pickup to the right-hand cylinder’s plug wire and check its timing at 3,500 RPM. The relative spark timing should be very close to that of the left-hand cylinder. Small differences can be “split” by repositioning the pickup plate a little, if desired. Generally, the timing will be as identical as printed-circuit board tolerances and Hall-effect device matching will allow.
68. When the desired timing has been set and verified, shut off the ignition power, close the petcock, reinstall the alternator rotor cover and points housing cover, and top up the oil level.

Appendix 1; kill switch and tachometer options

As noted in the wiring table earlier in this document, there are tachometer and kill switch options available. If you’ve completed the basic ignition system installation, you’ve already dealt with the four heavy-gauge wires that came pre-installed in the 6-pin power cable harness connector. The two remaining connector positions are associated with the tachometer and kill switch options. Their numbers are:

◆ Position 5:	Kill switch
◆ Position 6:	Tachometer output

The BT-45E installation kit includes one white and one orange wire that can be inserted into the 6-pin connector housing to make the kill switch and tachometer connections.

The terminals are preinstalled onto the ends of the wires; these may be inserted into the connector housing from the back (where the molded-in numbers are, and where the existing red, green, yellow, and blue wires are sticking out). The terminals install into the 6-pin connector housing in the same way that you installed the Pickup Plate wire terminals into the 8-pin housing in previous steps.

PROBE ENGINEERING, INC.

Installation Instructions, Model BT-45E

Version 3.2

The first option is the Kill Switch; this one's easy. If you install the kit's accessory white wire in connector position 5, and short the other end of the wire to chassis ground, the plugs will stop sparking for as long as the electrical connection is made. The kill function does NOT disable the ignition's control module or tachometer output; they continue to operate (the module alone draws only about 100 milliamperes). The kill function turns off the coil current, so that there can be no spark, and current draw is minimal.

If you wire in an old-fashioned momentary kill button (the kind with a single wire that shorts to the handlebar when activated) and push it with the engine running, both cylinders will stop firing for as long as you hold down the button. You can also use a toggle-type switch to ground, so that spark is interrupted when the switch is in the "kill" position.

The second option is the "digital" tachometer output signal (orange wire). The tachometer output is configured to give one signal pulse per crankshaft revolution; this is a common Japanese bike electronic-tachometer format for 4-cylinder bikes.

Electronic tachometers will generally have either three or four wires. The three-wire versions have the following connections:

- +12V
- Ground
- Signal Input

Four-wire tachometers have an additional dedicated lead for the internal backlight.

Color coding for these wires varies from manufacturer to manufacturer, so you will have to determine which is which according to your tachometer's documentation. The orange tachometer output wire of the ignition module would connect to the Signal Input wire of the tachometer.

PROBE ENGINEERING, INC.

Installation Instructions, Model BT-45E Version 3.2

Other details and notes:

- ◆ For those who are running high-compression, high-RPM applications and wish to use high-performance aftermarket coils, a coil with a primary resistance down to 3.0 ohms is permissible. Coils with 5.0 ohms primary resistance will work well, and have the benefit of drawing less current and running cooler. As previously noted, suppression-type sparkplug wire should be used with aftermarket coils (the OEM Honda coils often do not have replaceable plug wires).
- ◆ Coils intended for capacitive-discharge ignition (CDI) systems measure less than 1 ohm primary resistance, and are incompatible with the Model BT-45E ignition system. The use of CDI-type ignition coils will destroy the control module. Many inexpensive multimeters can't measure accurately down to a few ohms, so be especially careful to know what coil resistance you've really got.

For questions and/or assistance, contact:

Mark Whitebook
Probe Engineering, Inc.
34661 Calle Rosita
Capistrano Beach, CA 92624
mwhitebook@yahoo.com